

Pharmsteri™ PES Disposable Filter

Cost-effective, safe, sterile filtration for pharmaceutical applications

Pharmsteri™ PES disposable filters are designed to provide smart, disposable, safe filtration for pharmaceutical applications. Constructed of polypropylene (PP) components and a hydrophilic polyethersulfone (PES) membrane, these disposable filters can help eliminate cleaning problems and extra validation costs.

Our portfolio of Pharmsteri PES filters is 100% tested during manufacturing to ensure high quality performance, providing sterility assurance. The T-style configuration is ideal for quicker and easier installation.

APPLICATIONS

- Bioburden reduction or sterile filtration for injections
- Bulk chemicals
- Buffers

FEATURES & BENEFITS

Polypropylene and PES construction	Allows use in a broad range of applications
1.5" Tri-Clamp connector	Allows easier, user-friendly installation
Optimized form factor	Allows high flow and low pressure drop, lowering cost of ownership
All components meet USP <88> Class VI Plastics Test	Provides biosafety insurance and global regulatory compliance



Allows high flow and low hold-up volume of liquids.

SPECIFICATIONS

Retention rating	0.22, 0.45 μm	
Materials	Membrane	Polyethersulfone (PES)
	Housing, support	Polypropylene
	Sleeve, core, top, end caps	Polypropylene
	O-ring	Silicone
Sealing technology	Thermal bonding without adhesives	
Filtration area	10"	$\geq 0.6 \text{ m}^2$
	5"	$\geq 0.3 \text{ m}^2$
Integrity test (0.22 μm)	Minimum bubble point at 25°C (77°F)	$\geq 3500 \text{ mbar}$
	Maximum diffusion flow at 2800 mbar @ 25°C (77°F)	5": $\leq 15 \text{ mL/min}$
		10": $\leq 30 \text{ mL/min}$
Maximum operating conditions	Maximum forward differential pressure	3.5 bar @ 25° $\pm 2^\circ\text{C}$ (77°F), 3.0 bar @ 60° $\pm 2^\circ\text{C}$ (140°F)
Sterilization cycles	Maximum 5 cycles of autoclave @ 127°C (261°F), 30 min	
Endotoxin releasing	<0.25 EU/mL according to the USP test methodology	
TOC	<0.5 mg/L after a water flush of 11 L/10" filter	
Conductivity	$\leq 1.3 \mu\text{S/cm}$ after water flush of 11 L/10" filter	
Particle release	Meets the requirements of WFI set by USP	
NVR	After autoclaving and 24-hours in 50% ethanol water with vibration (contact Entegris for details)	
Material toxicity	All components meet the requirements of the USP <88> Reactivity Test for Class VI Plastics	
Bacterial challenge test	Passed the bacterial challenge test using <i>Brevundimonas diminuta</i> (ATCC 19146) at a minimum challenge concentration $1 \times 10^7 \text{ CFU/cm}^2$ (0.22 μm) per ASTM methodology	
Indirect food additive	Meets the FDA Indirect Food Additive requirements cited in 21 CFR 177-182	
Food contact material	(EU) No. 1935/2004, (EU) No. 10/2011	
Quality	Manufactured in accordance with ISO 9001 and ISO 13485 certified quality management system	

PERFORMANCE DATA

Flow Rate for 0.22 μm

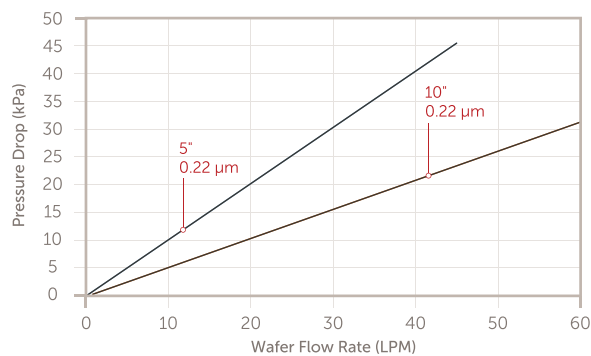

Flow Rate for 0.45 μm

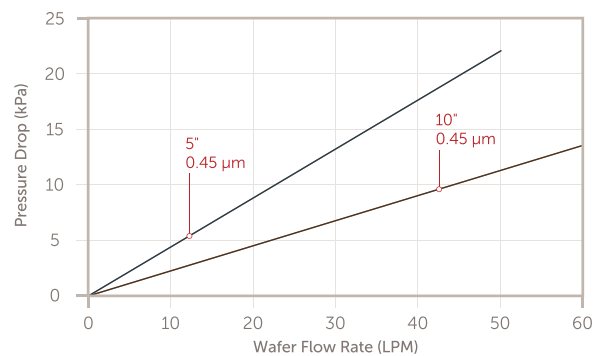

DIMENSIONS

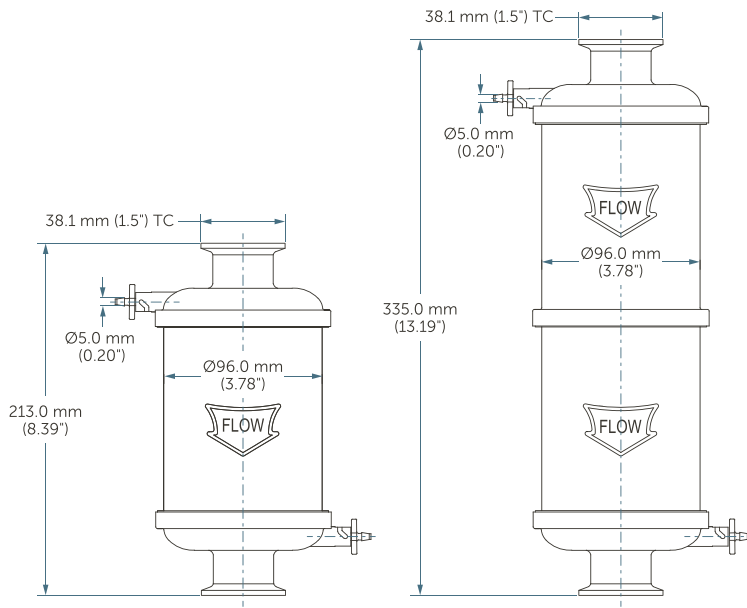

ORDERING INFORMATION

PART NUMBER	RETENTION RATING	LENGTH
PSTSUS022FS05-A2	0.22 µm	5"
PSTSUS022FS10-A2	0.22 µm	10"
PSTSUS045FS05-A2	0.45 µm	5"
PSTSUS045FS10-A2	0.45 µm	10"

FOR MORE INFORMATION

Please call your Regional Customer Service Center today to learn what Entegris can do for you. Visit [entegris.com](https://www.entegris.com) and select the [Contact Us](#) link to find the customer service center nearest you.

TERMS AND CONDITIONS OF SALE

All purchases are subject to Entegris' Terms and Conditions of Sale. To view and print this information, visit [entegris.com](https://www.entegris.com) and select the [Terms & Conditions](#) link in the footer.



Corporate Headquarters
129 Concord
Billerica, MA 01821
USA

Customer Service
Tel +1 952 556 4181
Fax +1 952 556 8022
Toll Free 800 394 4083

Entegris®, the Entegris Rings Design®, and other product names are trademarks of Entegris, Inc. as listed on [entegris.com/trademarks](https://www.entegris.com/trademarks). All third-party product names, logos, and company names are trademarks or registered trademarks of their respective owners. Use of them does not imply any affiliation, sponsorship, or endorsement by the trademark owner.