

NOWPak[®] Bottle System

Liner-based bottle system with a pre-cleaned, two-ply, heat-sealed PTFE T420 liner

The NOWPak[®] liner-based bottle system is a leading containment and dispense system that helps ensure that chemicals are protected throughout the filling, shipping and dispensing operations. The system includes a container which consists of a flexible liner inside a rigid overpack, a package closure and a variety of dispense connector options.



NOWPak liner-based bottle system with temporary shipping cap, shown in amber color

APPLICATIONS

- NOWPak systems are designed for applications that require containment and safe transport of liquids that have high-purity requirements and/or are sensitive to the environment.

FEATURES & BENEFITS

- Liners are particle tested and certified
- System dispenses chemical through a sealed pathway from liner to dispense tool, protecting chemical from external contamination
- Amber color HDPE overpacks contain a UV block additive to protect light-sensitive chemicals
- Collapsible liner system helps maximize chemical utilization
- Paired with the SmartCap[™] or IntelliCap[™] closure and ErgoNOW[™] connector, key-coding feature helps prevent dispensing the wrong material

SPECIFICATIONS

Materials of construction	Liner	PTFE film
	Fitment	Injection molded natural virgin PFA
	Retainer	Injection molded natural virgin HDPE
	Overpack	Blow molded HDPE
	Chime (20-liter size)	Injection molded natural virgin HDPE
	Temporary cap	Injection molded LDPE – red pigmented
Cleanliness	<p>Product is not to exceed 96 particles per mL at ≥ 60 nm in ultrapure DI water</p> <p>Product is not to exceed 36 particles per mL at ≥ 80 nm in ultrapure DI water</p> <p>Product is not to exceed 14 particles per mL at ≥ 100 nm in ultrapure DI water</p> <p>A Certificate of Analysis stating lot specific particle count data is available for each shipment of product.</p>	
Extractable trace elements	<p>Product is not to exceed 1.3 parts-per-billion (ppb) total of extractable trace elements listed utilizing 5% nitric acid. Trace elements reported are Ag, Al, As, B, Ba, Bi, Ca, Cd, Co, Cr, Cu, Fe, In, K, Li, Mg, Mn, Na, Ni, Pb, Si, Sn, Sr, Ti, V, W, and Zn.</p> <p>A Certificate of Analysis stating lot specific trace element data is available for each shipment of product.</p>	
Total siloxanes*	Product is not to exceed 0.915 ppb	
Total volatile organic compounds*	Product is not to exceed 16.774 ppb	
UV protection	Less than 0.1% light transmittance at 190 – 400 nm wavelength (amber color)	
Dispense pressure rating	The NOWPak container is not a pressure rated vessel. Pressurization maximum 34 kPa (5 psig) for maximum two minutes.	
Application torque for closures	9.04 – 9.60 N•m (80 – 85 in•lb)	
United Nations classification	1 – 10 liter sizes	A combination package with an Entegris specified shipping box; Certified UN4G/X and UN4G/Y
	20 liter size	Single packaging Certified 1H1/Y1.7/100/**
Overpack neck thread	Modified 63 mm buttress thread, 4.24 mm (0.167") pitch	
Manufacturing standards	Fabricated and tested in a Class 5 Cleanroom as per International Standard ISO 14644-1:*** Cleanrooms and associated controlled environments – Part 1: Classification of air cleanliness.	
	Film and heat-seal defect detection	Light table visual inspection; Inspection frequency 100%
	Liner leak detection	Pressure decay tested; Test frequency 100%; Pass/fail test
	Weld integrity verification	Pressurized burst tested. Minimum burst strength 16.2 psi; Test frequency 1:100 Weld tensile strength tested. Film/film: Minimum tensile strength 5 in•lb energy at break; Test frequency 1:100 Fitment weld strength tested: Pass/fail test Test frequency 1:100
	Particle count verification	Particle testing with ultrapure DI water Test frequency 2:100

* Total siloxanes and volatile organic compounds specifications apply only to 4-liter NOWPak bottle system assemblies and replacement liners.

** Year

*** ISO standard certification is kept up to date as necessary to remain current and effective to be able to demonstrate compliance with up-to-date ISO requirements.

SPECIFICATIONS (CONTINUED)

Container cosmetic appearance	Free from flash, burrs, color variations, and visual residue or visible particles per Entegris standards.		
Shelf life	The shelf life on NOWPak bottle systems, closures and replacement liners is at least two years, when said products are stored in a reasonably controlled environment. Entegris utilized accelerated test techniques, including temperature cycling, to generate the supporting data.		
Country of assembly	U.S.A.		
Rated capacity and weight***	PART NUMBER	RATED CAPACITY	NOMINAL WEIGHT OF CONTAINER (INCLUDING TEMPORARY CAP)****
	NP-01-XX-T420-1	1 Liter	215 g (0.47 lb)
	NP-02-XX-T420-1	2.5 Liters	289 g (0.64 lb)
	NP-04-XX-T420-1	4 Liters	445 g (0.98 lb)
	NP-04-XX-T420-1A	4 Liters	445 g (0.98 lb)
	NP-10-XX-T420-1	10 Liters	762 g (1.68 lb)
	NP-20-XX-T420-1	20 Liters	2005 g (4.42 lb)

*** **WARNING: DO NOT OVERFILL.** There is a designed overhead capacity to accommodate the dispense system. The actual capacity should be used when filling the NOWPak bottle to avoid process problems and potential overflows.

**** A temporary cap weighs 7 g.

DIMENSIONS

Note: Unless otherwise indicated, all numeric values are nominal.
Drawings are not to scale.

3/4" Fitment

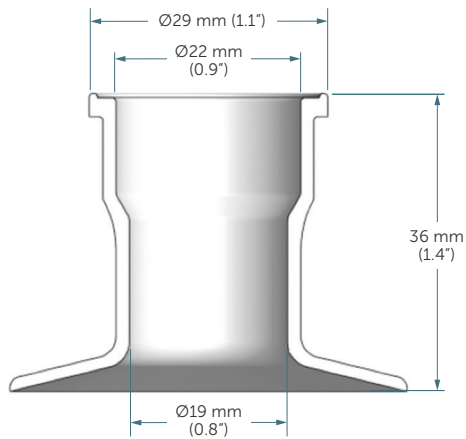

Temporary Shipping Cap

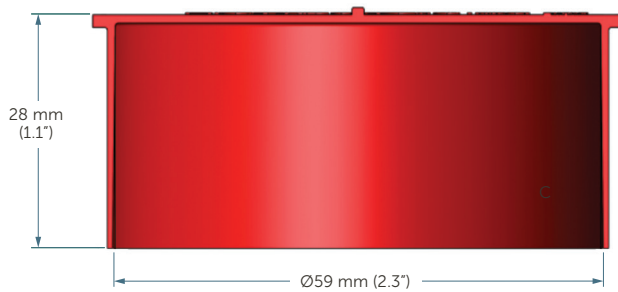

DIMENSIONS (CONTINUED)

1 Liter

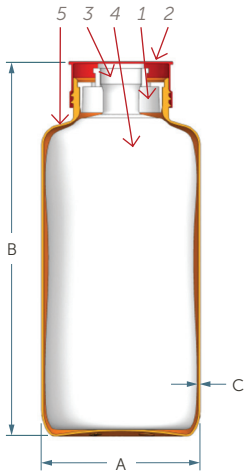

2.5 Liter

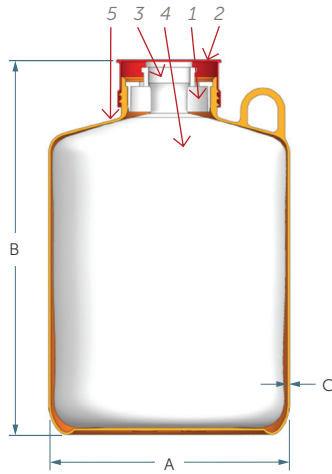

4 Liter

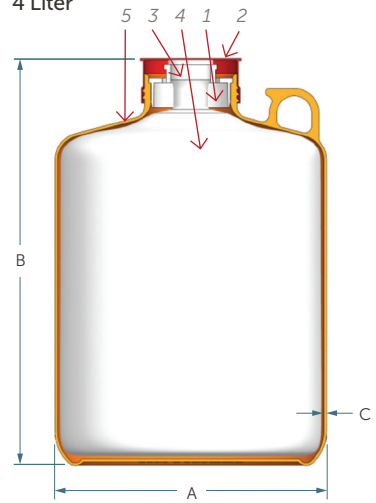

10 Liter

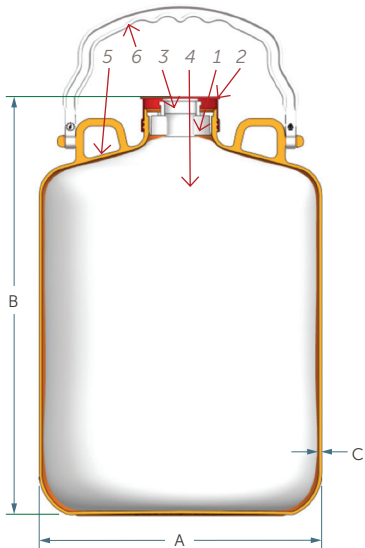

20 Liter

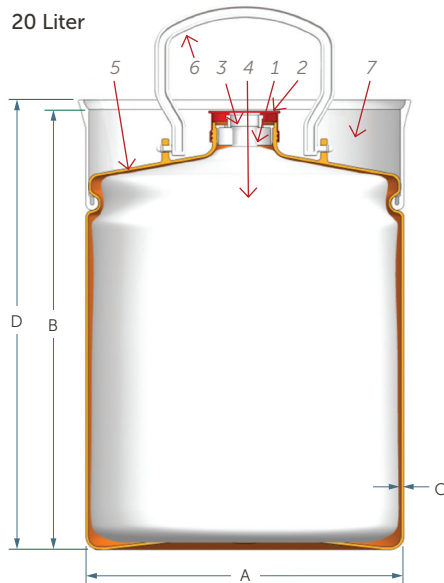

Item	Description	Qty
1	Retainer	1
2	Temporary cap	1
3	Fitment	1
4	PTFE liner	1
5	Overpack	1
6	Handle	1
7	Chime ring	1

Note: NOWPak bottle shown in amber color. Not drawn to scale.

DIMENSIONS

Part number	Size	A Container outside diameter	B Height to top of temp cap (max)	C Container wall thickness (min)	D Height to top of chime ring
NP-01-XX-T420-1	1 L	99 mm (3.9")	235 mm (9.3")	1.0 mm (0.04")	N/A
NP-02-XX-T420-1	2.5 L	149 mm (5.9")	234 mm (9.2")	1.0 mm (0.04")	N/A
NP-04-XX-T420-1 NP-04-XX-T420-1A	4 L	175 mm (6.9")	268 mm (10.6")	1.3 mm (0.05")	N/A
NP-10-XX-T420-1	10 L	230 mm (9.1")	344 mm (13.6")	1.3 mm (0.05")	N/A
NP-20-XX-T420-1	20 L	305 mm (12.0")	402 mm (15.8")	1.5 mm (0.06")	416 mm (16.4")

SHIPPING INFORMATION

Labeling	A liner barcode label showing the assembly part number, bottling batch number, and liner lot number is applied to the bottom surface of the overpack. The outer shipping box is labeled with part number, product description, bottle batch number, liner lot number(s), quantity and date of manufacture.
Packaging	<p>For NP-XX-X1-T420-1 (1 to 10 liter sizes):</p> <p>NOWPak bottles are double-wrapped in a polyethylene bag and closed with a cable tie. The double-wrapped NOWPak bottles are placed into a shipping box made of corrugated fiberboard.</p> <hr/> <p>For NP-04-A1-T420-1A (4 liter size only):</p> <p>NOWPak bottles are placed six bottles to a pre-form tray. Two trays of six (12 bottles) are then bagged and sealed. Two of the bags of 12 are stacked, bagged and sealed. This bag of 24 is then placed into a shipping box made of corrugated fiberboard.</p> <hr/> <p>For NP-20-XX-T420-1 (20 liter size):</p> <p>Minimum order quantity – 16 units per skid. Bulk packaged 16 units per skid, (four rows of four, one row high). Shrink wrapped overall. Economic order quantity – Bulk packaged 64 units per skid (16 units per row, four rows high). Slip sheet is placed between each row and shrink wrapped overall.</p>

Part number	Size	Box quantity (minimum order quantity)	Skid quantity (economic order quantity)	Box dimensions (L x W x H)
NP-01-XX-T420-1	1 L	50	700 (14 boxes of 50)	1003 mm x 508 mm x 273 mm (39.5" x 20" x 10.7")
NP-02-XX-T420-1	2.5 L	40	320 (8 boxes of 40)	762 mm x 635 mm x 508 mm (30" x 25" x 20")
NP-04-XX-T420-1	4 L	25	250 (10 boxes of 25)	762 mm x 635 mm x 508 mm (30" x 25" x 20")
NP-04-XX-T420-1A	4 L	24	240 (10 boxes of 24)	762 mm x 635 mm x 508 mm (30" x 25" x 20")
NP-10-XX-T420-1	10 L	18	144 (8 boxes of 18)	711 mm x 457 mm x 1067 mm (28" x 18" x 42")
NP-20-XX-T420-1	20 L	N/A	16 per skid	N/A
	20 L	N/A	64 per skid	N/A

ORDERING INFORMATION

NOWPak Liner-based Bottle System Assembly: part number

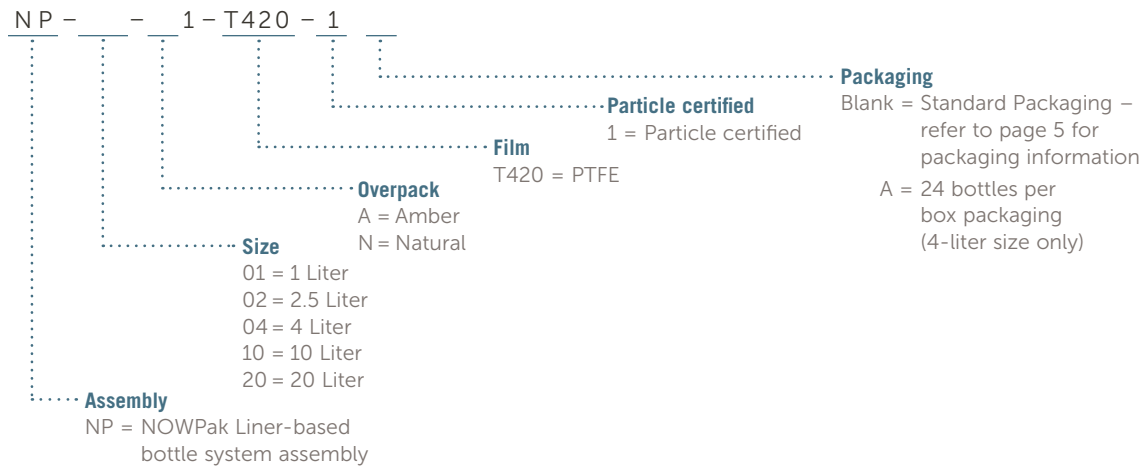

NOWPak Liner-based Bottle System Accessories

Part number	Description
NC-W1	Breakseal closure, 63 mm thread, white
NC-W2	Removable closure, 63 mm thread, white
SC-XX-YY-ZZ*	SC type SmartCap with customer-specific key-code
SCD-XX-YY-ZZ*	SCD type SmartCap with customer-specific key-code
SCG-XX-YY-ZZ*	SCG type SmartCap with customer-specific key-code
TC-W1-10	IntelliCap with universal closure, quantity of 10
TC-W1-50	IntelliCap with universal closure, quantity of 50
NA-02	Torque tool adapter for NC-W1 breakseal style closure (fits on a 1/2" drive torque wrench)
NA-03	Torque tool adapter for NC-W2 thread-on/off style closure (fits on a 1/2" drive torque wrench)
NA-51	Torque tool adaptor for SmartCap and IntelliCap closures, includes 1/2" torque drive adaptor
NA-51-A-XXYYZZ*	Torque tool for SmartCap and IntelliCap closures with keyed insert (XXYYZZ represents key-code)
NA-51-XXYYZZ*	Keyed Insert for NA-51-A-XXYYZZ SmartCap torque tool (XXYYZZ represents key-code)
NA-42	Torque tool adapter, SmartCap and IntelliCap
NA-33	Torque wrench, 3/8", 0 – 150 lb•in with 3/8" to 1/2" adapter
NA-47	Tear tab removal tool for SmartCap and IntelliCap closures, Delrin
NA-47-SS	Tear tab removal tool for SmartCap and IntelliCap closures, stainless steel
NA-06	Liner removal tool
NA-07-100	Liner disposal plugs, bag of 100

* For assistance with setting up customer-specific key-codes, please contact Entegris.

FOR MORE INFORMATION

Please call your Regional Customer Service Center today to learn what Entegris can do for you. Visit [entegris.com](https://www.entegris.com) and select the [Contact Us](#) link to find the customer service center nearest you.

TERMS AND CONDITIONS OF SALE

All purchases are subject to Entegris' Terms and Conditions of Sale. To view and print this information, visit [entegris.com](https://www.entegris.com) and select the [Terms & Conditions](#) link in the footer.



Corporate Headquarters

129 Concord Road
Billerica, MA 01821
USA

Customer Service

Tel +1 952 556 4181
Fax +1 952 556 8022
Toll Free 800 394 4083

Entegris®, the Entegris Rings Design®, and other product names are trademarks of Entegris, Inc. as listed on [entegris.com/trademarks](https://www.entegris.com/trademarks). All third-party product names, logos, and company names are trademarks or registered trademarks of their respective owners. Use of them does not imply any affiliation, sponsorship, or endorsement by the trademark owner.

©2016-2024 Entegris, Inc. | All rights reserved. | Printed in the USA | 7119-8167ENT-1024