

NOWPak® T420 PTFE Replacement Liner

*Pre-cleaned, two-ply, heat-sealed
replacement PTFE T420 liner*

The PTFE T420 replacement liner is designed for use with the NOWPak® liner-based canister and bottle systems. The liner helps provide ultraclean chemical dispensing without direct contact between the chemical and drive gas. Replacement liners are available in 1-, 2.5-, 4-, 10-, 18-, and 19/20-liter sizes.

APPLICATIONS

- NOWPak systems are designed for applications that require containment and safe transport of liquids that have high-purity requirements and/or are sensitive to the environment



PTFE T420 Replacement Liner

FEATURES & BENEFITS

- Liners are particle tested and certified
- Liner-based system minimizes risk of environmental contamination
- Collapsible liner system helps maximize chemical utilization
- System dispenses chemical through a sealed pathway from liner to dispense tool, protecting chemical from external contamination
- Liners are pre-folded to ensure easy insertion into the canister or overpack
- Liners are easily removed for disposal, resulting in minimal waste

SPECIFICATIONS

Materials of construction	Film	PTFE, natural translucent color
	Fitment	Injection molded, virgin PFA
	Retainer	Injection molded, virgin HDPE
	Temporary cap	Injection molded, red pigmented LDPE
	Liner sleeve	PE
Manufacturing standards	Fabricated and tested in a Class 5 Cleanroom as per International Standard ISO 14644-1:* Cleanrooms and associated controlled environments – Part 1: Classification of air cleanliness.	
	Film and heat-seal defect detection	Light table visual inspection. Inspection frequency 100%.
	Liner leak detection	Pressure decay tested. Test frequency 100%. Pass/fail test.
	Weld integrity verification	Pressurized burst tested. Minimum burst strength 16.2 psi. Test frequency 1:100. Weld tensile strength tested. Film/film: Minimum tensile strength 5 in•lb energy at break. Test frequency 1:100. Fitment weld strength tested: Pass/fail test. Test frequency 1:100.
	Particle count verification	Particle testing with ultrapure DI water. Test frequency 2:100.
Cleanliness	<p>Product is not to exceed 96 particles per mL at ≥ 60 nm in ultrapure DI water.</p> <p>Product is not to exceed 36 particles per mL at ≥ 80 nm in ultrapure DI water.</p> <p>Product is not to exceed 14 particles per mL at ≥ 100 nm in ultrapure DI water.</p> <p>A Certificate of Analysis stating batch-specific particle count data is available for each shipment of product.</p>	
Extractable trace elements	Product is not to exceed 1.3 parts-per-billion (ppb) total of extractable trace elements listed utilizing 5% nitric acid. Trace elements reported are Ag, Al, As, B, Ba, Bi, Ca, Cd, Co, Cr, Cu, Fe, In, K, Li, Mg, Mn, Na, Ni, Pb, Si, Sn, Sr, Ti, V, W and Zn.	
Total siloxanes**	Product is not to exceed 0.915 ppb	
Total volatile organic compounds**	Product is not to exceed 16.774 ppb	

*ISO standard certification is kept up to date as necessary to remain current and effective to be able to demonstrate compliance with up-to-date ISO requirements.

**Total siloxanes and volatile organic compounds specifications apply only to 4-liter size NOWPak bottle system replacement liners.

DIMENSIONS

Fitment

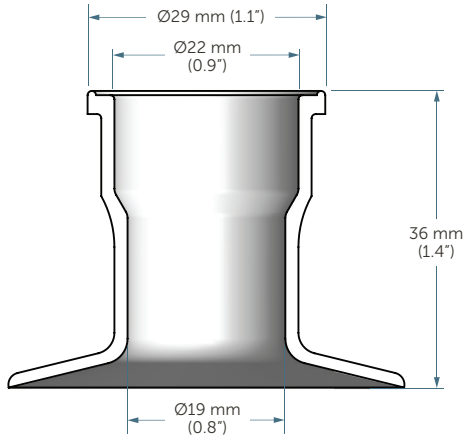

Liner

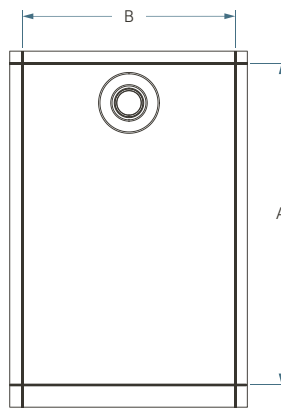

PART NUMBER			DIMENSIONS		
Liner	Canister*	Bottle overpack**	Size	A	B
NL-001-T420A-1	N/A	NO-01-A	1 L	305 mm (12.0")	165 mm (6.5")
NL-002-T420A-1	N/A	NO-02-N	2.5 L	330 mm (13.0")	251 mm (9.9")
NL-004-T420A-1	NO-04 NO-04-63	NO-04-A	4 L	406 mm (16.0")	299 mm (11.8")
NL-010-T420A-1	NO-05 NO-05-63	NO-05-A NO-05-N	10 L	533 mm (21.0")	406 mm (16.0")
NL-018-T420A-1	NO-09 NO-09-63	N/A	18 L	730 mm (28.8")	362 mm (14.3")
NL-020-T420A-1	NO-08 NO-08-63 (19-liter canister)	NO-06-A NO-06-N (20-liter bottle)	19/20 L	679 mm (26.8")	489 mm (19.3")
NL-020-T420B-1	NO-07 NO-07-1 (20-liter canister)	N/A	20 L	597 mm (23.5")	489 mm (19.3")

Notes:

- All dimensions are measured inside to inside of weld.
- For 1-liter size: A and B dimensions are ± 3 mm (0.13").
- For 2.5- to 20-liter sizes: A and B dimensions are ± 6 mm (0.25").
- * -63 designates canisters with modified buttress 63 mm neck thread; -1 designates corrosion prevention coating.
- ** -A designates amber colored bottle; -N designates natural color bottle.

SHIPPING INFORMATION

Labeling	Each liner is labeled with batch and part number. Each shipping carton and PE cleanroom bag is labeled with the part number, batch numbers and quantity of liners.
Packaging	Each liner is capped, folded and inserted into a cleanroom sleeve (heat sealed), then bulk packaged in a corrugated carton, lined with a PE cleanroom bag, 50 liners per box. Retainers are packaged in cleanroom conditions and shipped in the same quantity as the liner.

Part number	Size	Box quantity (minimum order quantity)	Skid quantity (economic order quantity)	Box dimensions (L x W x H)
NL-001-T420A-1	1 L	50	1,250 (25 boxes of 50)	660 mm x 457 mm x 356 mm (26.0" x 18.0" x 14.0")
NL-002-T420A-1	2.5 L	50	1,250 (25 boxes of 50)	660 mm x 457 mm x 356 mm (26.0" x 18.0" x 14.0")
NL-004-T420A-1	4 L	50	1,250 (25 boxes of 50)	660 mm x 457 mm x 356 mm (26.0" x 18.0" x 14.0")
NL-010-T420A-1	10 L	50	1,250 (25 boxes of 50)	660 mm x 457 mm x 356 mm (26.0" x 18.0" x 14.0")
NL-018-T420A-1	18 L	50	1,250 (25 boxes of 50)	667 mm x 413 mm x 394 mm (26.3" x 16.3" x 15.5")
NL-020-T420A-1	19/20 L	50	1,250 (25 boxes of 50)	667 mm x 413 mm x 394 mm (26.3" x 16.3" x 15.5")
NL-020-T420B-1	20 L	50	1,250 (25 boxes of 50)	667 mm x 413 mm x 394 mm (26.3" x 16.3" x 15.5")

ORDERING INFORMATION

NOWPak System Replacement PTFE Liner: part number

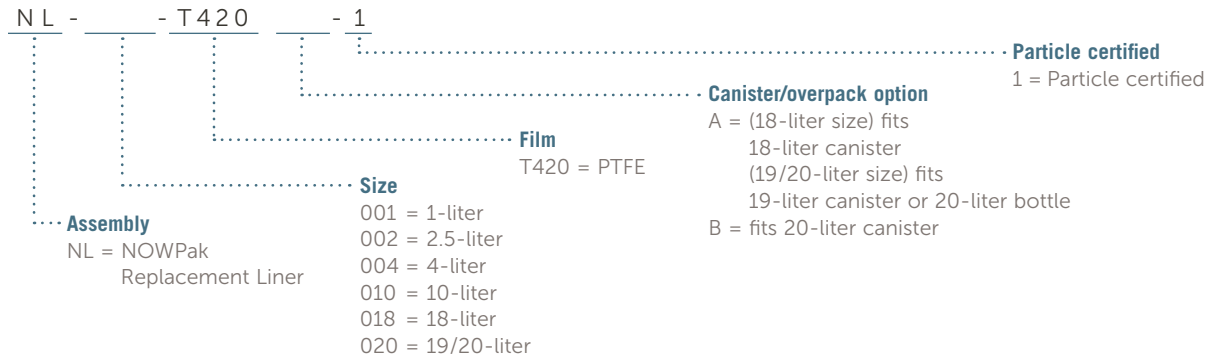

NOWPak system replacement PTFE liner accessories

Part number	Description
NA-60	Liner insertion tool
NA-06	Liner removal tool
NA-17	Liner removal and drain tool
NA-13	Diptube removal tool
NA-07-100	Liner disposal plug, bag of 100
NF-01-FR	Automatic bag inflation fixture for 4- to 20-liter liners
NA-41	Manual bag inflation connector for 4- to 20-liter liners, 63 mm buttress thread
NA-41-8990	Manual bag inflation connector for 4- to 20-liter liners, 2.5-12 UN thread

FOR MORE INFORMATION

Please call your Regional Customer Service Center today to learn what Entegris can do for you. Visit entegris.com and select the [Contact Us](#) link to find the customer service center nearest you.

TERMS AND CONDITIONS OF SALE

All purchases are subject to Entegris' Terms and Conditions of Sale. To view and print this information, visit entegris.com and select the [Terms & Conditions](#) link in the footer.



Corporate Headquarters

129 Concord Road
Billerica, MA 01821
USA

Customer Service

Tel +1 952 556 4181
Fax +1 952 556 8022
Toll Free 800 394 4083

Entegris®, the Entegris Rings Design®, and other product names are trademarks of Entegris, Inc. as listed on entegris.com/trademarks. All third-party product names, logos, and company names are trademarks or registered trademarks of their respective owners. Use of them does not imply any affiliation, sponsorship, or endorsement by the trademark owner.

©2017-2024 Entegris, Inc. | All rights reserved. | Printed in the USA | 7119-8310ENT-1024