

NOWPak® Bottle System Filling and Packaging Instructions

*U.S. UN box for six,
1-liter NOWPack bottles*

Procedure for filling, capping, and sealing NOWPak® bottle system one-liter assemblies with NA-11-01-6 UN box preparation, loading and box-sealing instructions. The NA-11-01-6 box holds six 1-liter NOWPak bottles.

INSTRUCTIONS

Bottle preparation and filling

1. Remove the red or blue temporary cap and visually inspect the NOWPak bottles for any visible defects.
2. Fill the NOWPak bottles with chemical, leaving adequate head space for possible liquid expansion.



Figure 1.

3. Obtain a new SmartCap™, NC-W1, or NC-W2 closure.
4. Visually confirm that closure components are in place, as shown in Figure 2.

5. Place the SmartCap, NC-W1, or NC-W2 closure on the NOWPak bottle and turn clockwise.

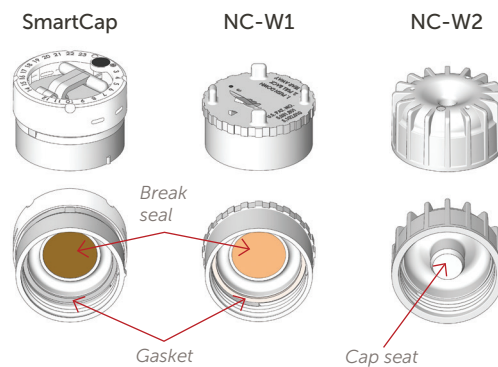

Figure 2.

Bottle sealing

Tools required:

Torque wrench	Part number NA-33 (available for purchase from Entegris) or User-supplied equivalent torque wrench (0 – 150 in•lb range torque wrench, with ½ square drive connection)
----------------------	---

	CLOSURE TYPE	APPLICABLE TORQUE ADAPTER
Torque adapter	SmartCap	NA-42 (universal) NA-51-A-XXYYZZ* (for specific key-coded closures)
	NC-W1	NA-02-03 (for specific key-coded closures) NA-02 (universal)
	NC-W2	NA-03

*XXYYZZ represents the key-code.

Torque specification

Minimum	Maximum	Unit
80	85	in•lbs
9.0	9.6	N•m
92	98	kgf•cm

1. Using a torque wrench and proper torque adapter per closure type, tighten the closure to the torque specification. Applicable adapters for each closure type and the torque specification are shown above.

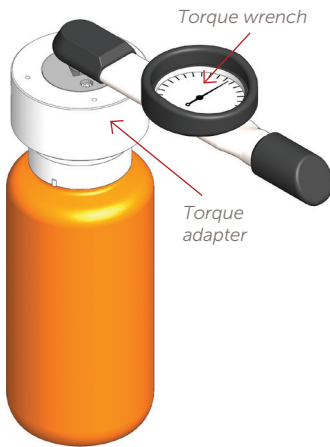

Figure 3.

Shipping box preparation and loading

1. Assemble the six by one-liter NOWPak bottle box by folding the opposing bottom flaps inward.
2. Seal the outer folded flaps to the box sides with two strips of 3M #375 pressure sensitive or equivalent tape. The tape must extend a minimum of two inches (5.08 cm) onto each side of the box, and should overlap at the seam.

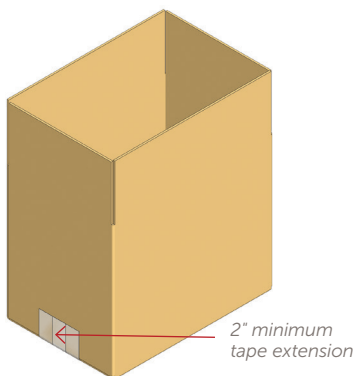

Figure 4.

3. Load the filled bottles into the box.

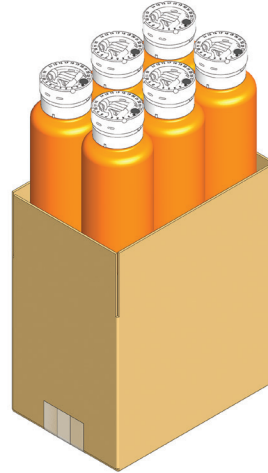

Figure 5. NA-11-01-6 with NOWPak bottles.

Shipping box closing and sealing

1. Close the box by folding the opposing top flaps inward.
2. Seal the outer folded flaps to the box sides with two strips of 3M #375 pressure sensitive or equivalent tape. The tape must extend a minimum of two inches (5.08 cm) onto each side of the box, and should overlap at the seam.

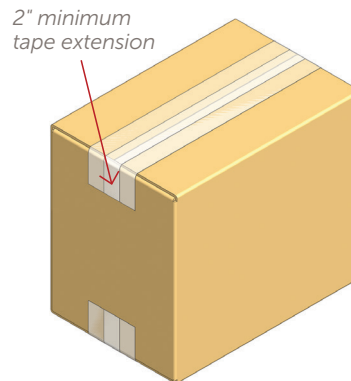

Figure 6. Closed box.

FOR MORE INFORMATION

Please call your Regional Customer Service Center today to learn what Entegris can do for you. Visit entegris.com and select the Contact Us link to find the customer service center nearest you.

TERMS AND CONDITIONS OF SALE

All purchases are subject to Entegris' Terms and Conditions of Sale. To view and print this information, visit entegris.com and select the Terms & Conditions link in the footer.



Corporate Headquarters

129 Concord Road
Billerica, MA 01821
USA

Customer Service

Tel +1 952 556 4181
Fax +1 952 556 8022
Toll Free 800 394 4083

Entegris®, the Entegris Rings Design™, Pure Advantage™, NOWPak®, and SmartCap™ are trademarks of Entegris, Inc.

©2017 Entegris, Inc. | All rights reserved. | Printed in the USA | 7119-8410ENT-0917